

## BRAKE TYPE 56

## SPRING APPLIED BRAKES

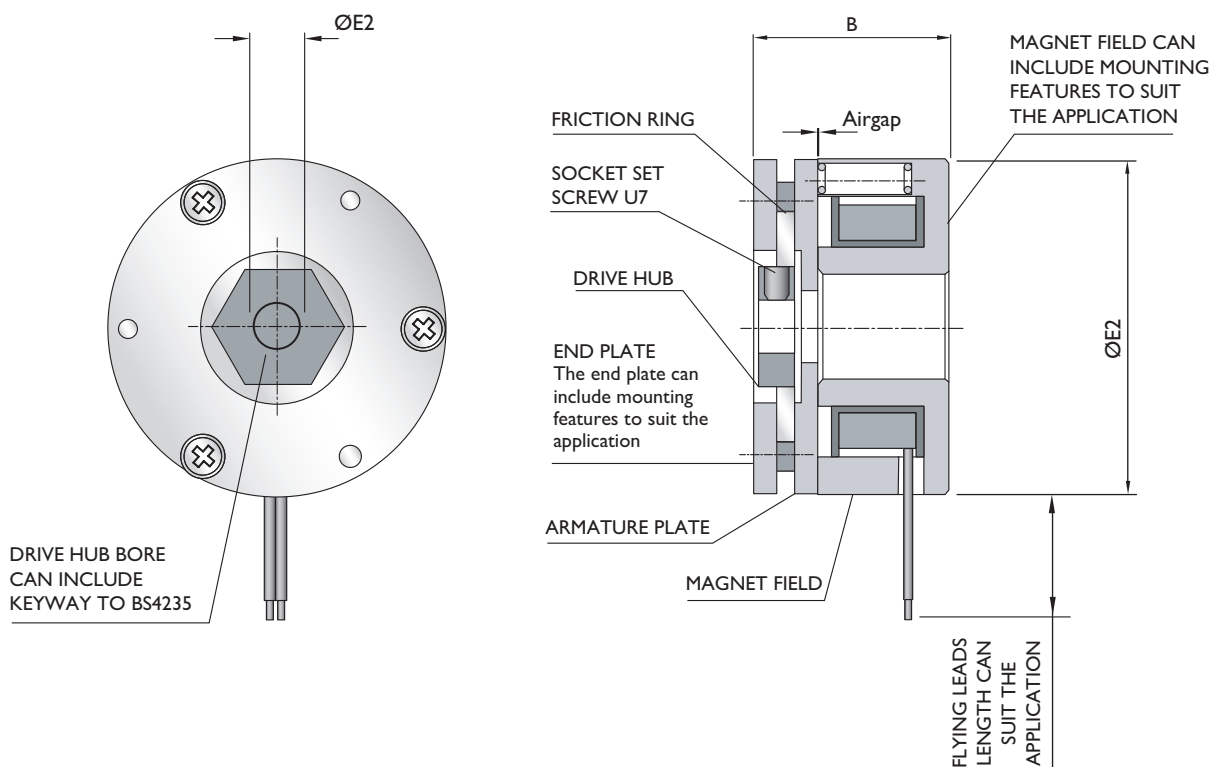

Spring-Applied brakes are used where a motor or drive must be held in the static-braking condition when power is lost, making them extremely useful in safety-conscious applications. This design of brake can be particularly desirable where low-costs are involved.

Brakes are supplied ready-to-fit and with the air-gap already pre-set. This means that the brake can be mounted directly to the motor without the need for any specialised tools.

Stephenson Gobin appreciates that the user can require many special features and will welcome any enquiries for spring-applied brakes whether shown on this data sheet or of a bespoke nature.

- Reliable, Static-Braking Operation,
- Durable Construction,
- Pre-set Air-Gap,
- Mounting Features to suit the Application,
- 12Vdc or 24Vdc Operation as Standard (other available on request).



SIZE	TORQUE (Nm)	POWER (P20)	A2	B	E2 (MAX)	U7
03	0.15	5	35	19.5	6	M3
04	0.5	5.5	40	26	8	M3
05	2.0	11	55	32.5	12	M4
07	5.0	20	75	43	14	M5