

THE MAGNETIC IMPACT OF SG TRANSMISSION

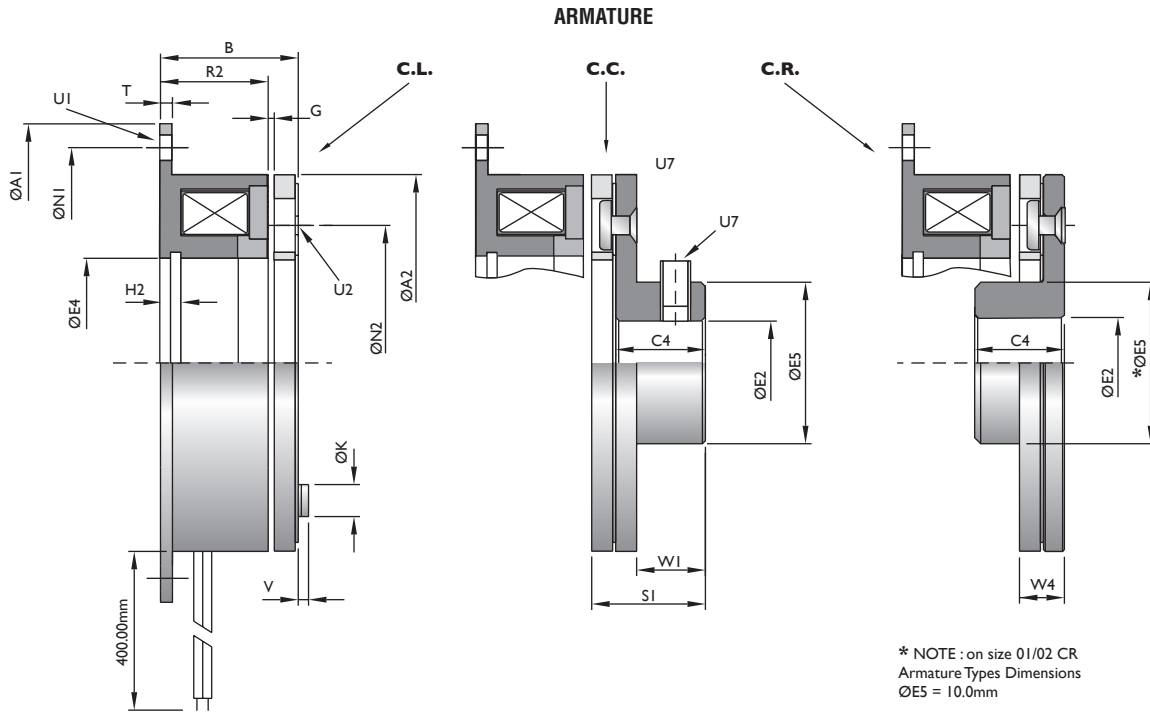

BRAKE TYPE 52

FIELD MOUNTING : F.M.



SIZE	Tro. TS (Nm)	Max P20 (w)	A1 h9	A2	B	C4	MAX E2 h7	E4 H8	E5	G	H2	K	N1	N2	R2	S1	T	U1 x4	U2	U7	V	W1	W4
00	0.30	5	38	28.6	17	7	6.5	11	10	0.1	-	5	33.3	19.5	14	9.7	1.5	3.2	2x2.6	M3	1	4.5	4.7
01	0.60	6	38	30	18.5	10	6.5	11.5	12	0.1	-	5	33.3	19.5	16	12.8	1.5	3.2	2x2.6	M3	1	8	-
02	0.75	6	45	32	19.5	10	6.5	13	12	0.1	3	5	38	23	17	12.8	2	3.5	3x2.6	M3	1.5	8	4.8
03	1.20	8	54	40	23.2	12	10	19	17	0.15	3.2	6.1	47	30	20	15.3	2	3.5	3x3.1	M3	1.5	9.5	5.8
04	1.60	8	62	42	23.2	12	10	19	17	0.15	-	6.1	54	29	20	15.3	2	5	2x3.1	M3	1.5	9.5	5.8
05	3	10	65	50	25.2	12	15	26	24	0.2	3.2	6.1	58	38	22	15.3	2	3.5	3x3.1	M4	1.5	9.5	6
06	8	12	80	63	22	15	17	35	27	0.2	3.5	6.1	72	46	18	19	2	4.5	3x3.1	M5	1.5	11.5	7.5
07	8	12	89	66.5	36	15	17	27	27	0.2	-	6.1	79.5	46	32	19	2	5	3x3.1	M5	1.5	11.5	-
08	16	18	100	80	24.5	20	20	42	32	0.2	4.3	8	90	60	20	24.7	2.5	5.3	3x4.1	M5	2	16	8.7
10	32	25	125	100	28	25	30	52	42	0.2	5	9	112	76	22	30	3	6.5	3x5.1	M6	2	19	11
11	32	25	143	105	44	25	30	47.6	42	0.2	-	9	127	76	38	30	3	7.5	3x5.1	M6	2	19	-
12	65	32	150	125	31	30	35	62	49	0.3	5.5	10	137	95	24	37.2	3.5	6.5	3x6.1	M6	2.5	24	13
13	65	32	165	125	39	30	35	52.4	49	0.3	-	10	149	95	33	37.2	3.5	10.2	3x6.1	M6	2.5	24	-
16	120	45	190	160	35	38	40	80	65	0.3	6	13	175	120	26	48	4	9	3x8.2	M8	9	30	16
20	240	60	230	200	41.6	48	60	100	92	0.5	7	16	215	158	30	59	5	9	3x10.2	M8	11	39	20

Keyways to B.S. 4235 • Circlip Grooves to B.S. 3673 • Insulation Class B

